

The instruments can be laid out in any variation. For all layouts, a 3' perimeter (minimum) is recommended around each instrument to allow for wheel chair accessibility (not required for wall mount). Instruments are to be installed in accordance with the manufacturer's specifications. The circular layout is intended to offer the most interaction between players. The following layouts are recommendations. Drawings are 1:20 scale.

WALL MOUNT LAYOUT

NOTE: INSTRUMENTS CAN BE PLACED IN ANY ORDER

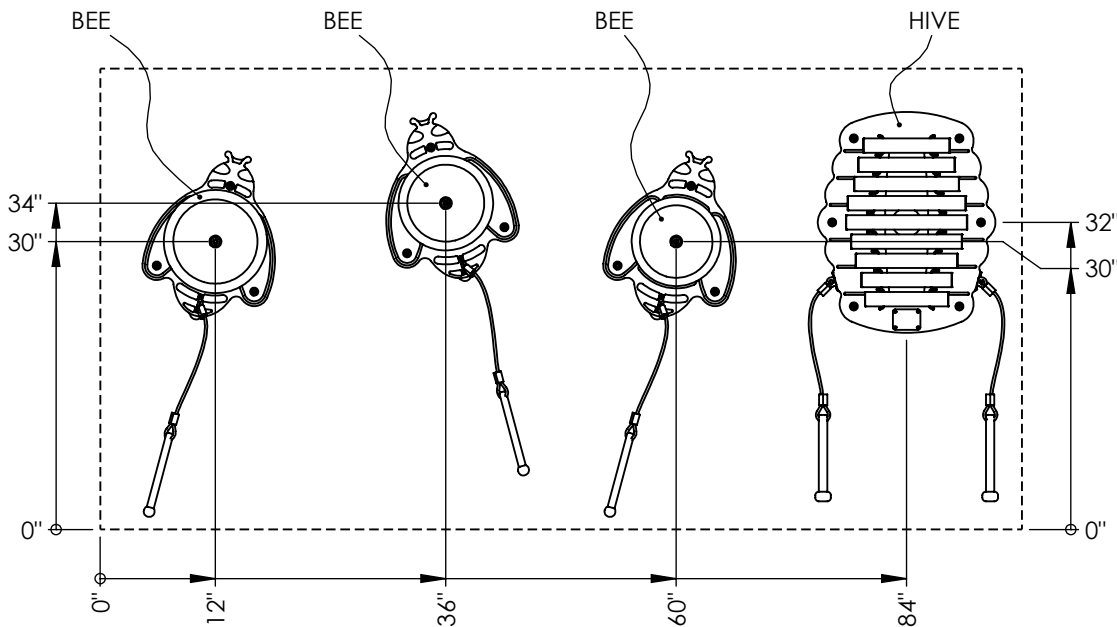

NOTE: INSTRUMENTS MAY BE ANGLED SLIGHTLY FOR A MORE DYNAMIC APPEARANCE.

HEIGHTS ARE SHOWN INSTALLED AT TODDLER LEVEL (2-5 YEARS). FOR AGES 5-12, INCREASE HEIGHTS BY NO MORE THAN 13". FOR ADULTS, INCREASE HEIGHTS BY APPROX. 20"

STRAIGHT LAYOUT

NOTE: INSTRUMENTS CAN BE PLACED IN ANY ORDER

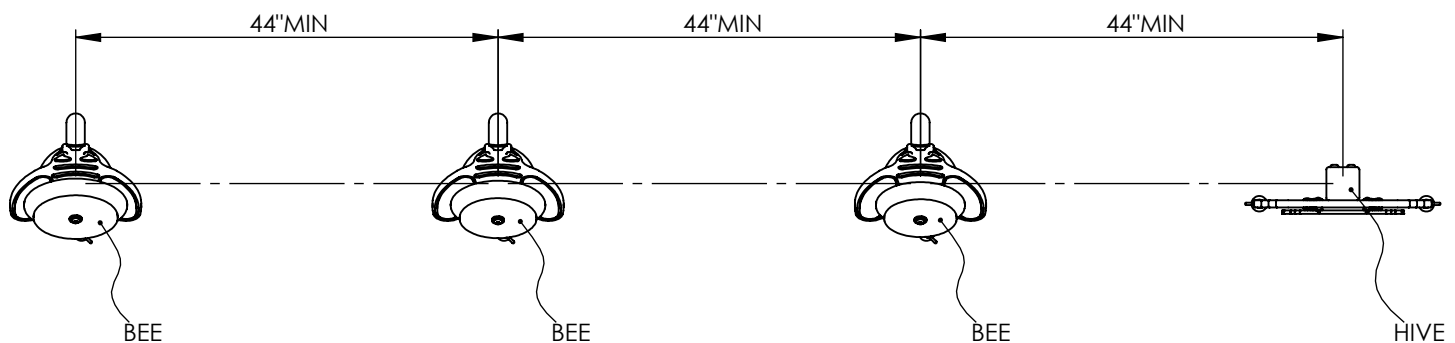

CIRCULAR LAYOUT

NOTE: INSTRUMENTS CAN BE PLACED IN ANY ORDER.

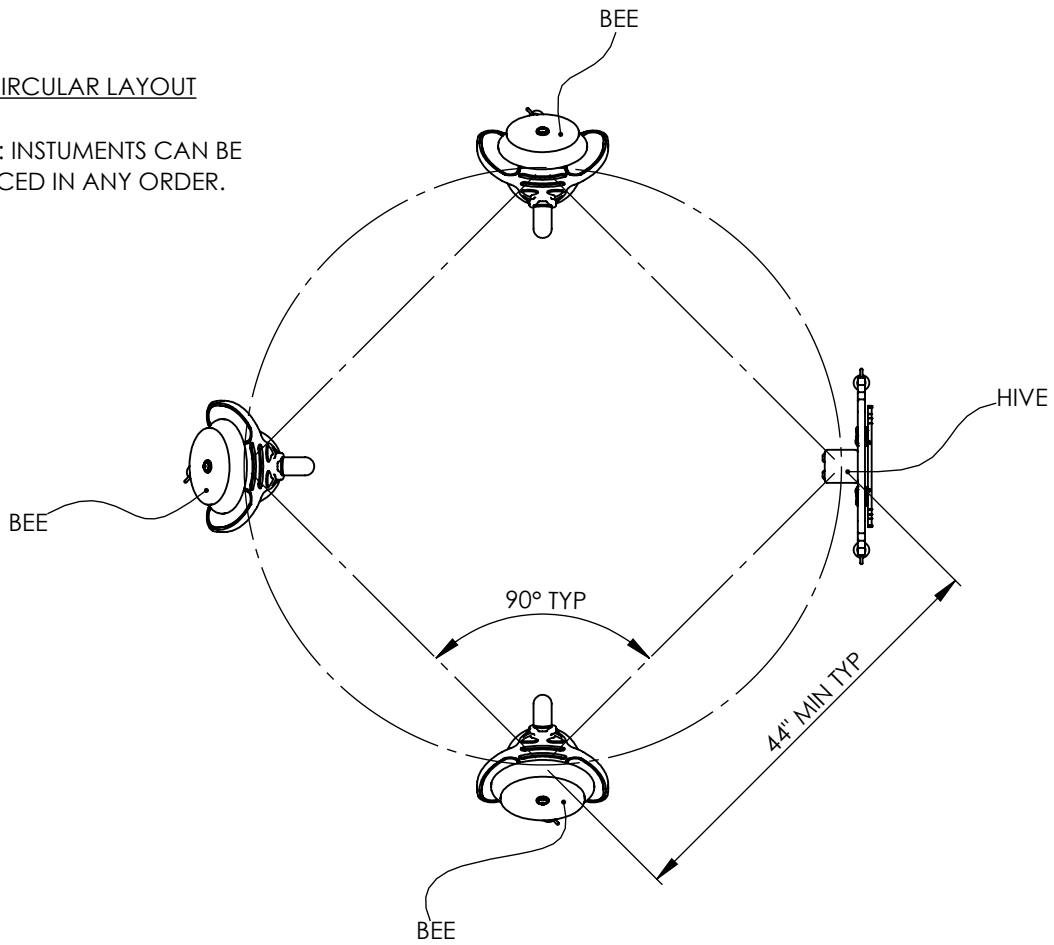

NOTE: ROTATE ALL INSTRUMENTS 180 DEG. FOR AN OPPOSITE CURVED LAYOUT.

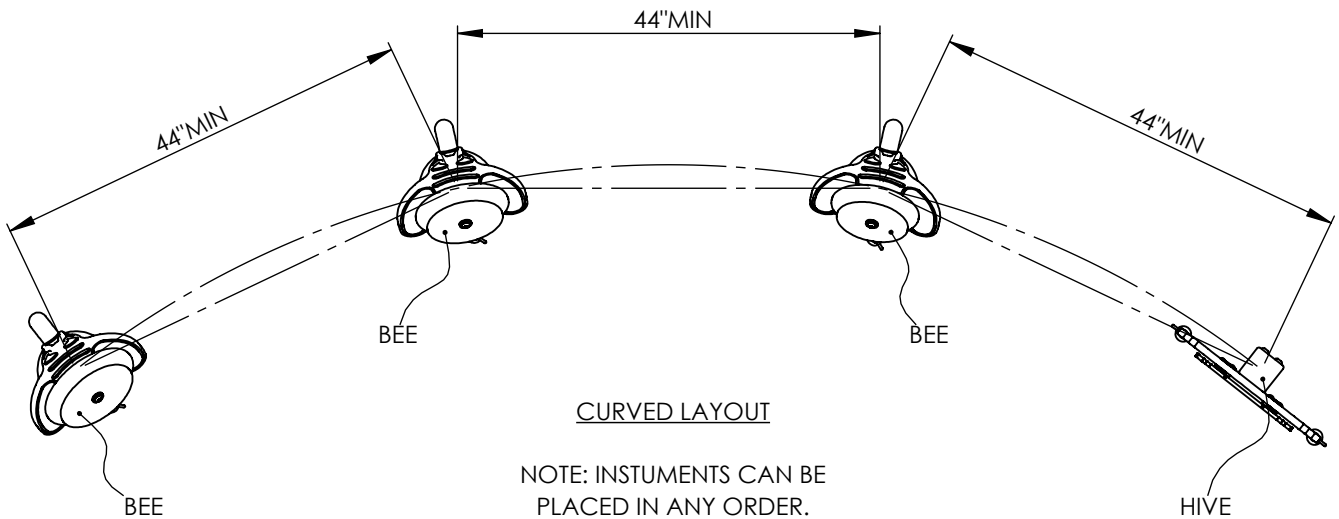

CURVED LAYOUT

NOTE: INSTRUMENTS CAN BE PLACED IN ANY ORDER.