

CONTENTS

- Sheet 1: Basic Information
- Sheet 2: Bill of Materials
- Sheet 3: In Ground Mount
- Sheet 4: Surface Mount
- Sheet 5: Portable Mount

INSTRUMENT INFO

- Scale: C Major Diatonic
- Notes: (Left to Right): B, G, E, C, A, D, F, A, C
- Bars: Fiberglass
- Frame: HDPE
- Post: HDPE or Powder Coated Steel
- Mallets: (2) Standard, 80 Durometer w/ 21" Cable



STANDARD HEIGHT

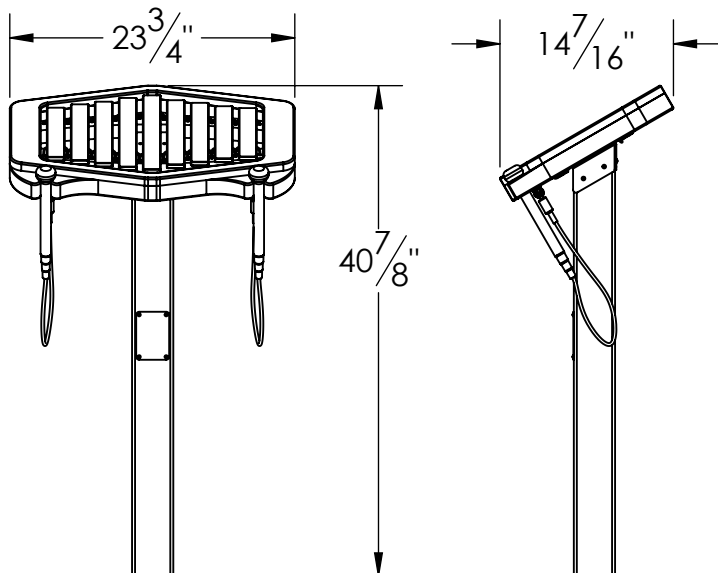

ASTM ADJUSTED HEIGHT

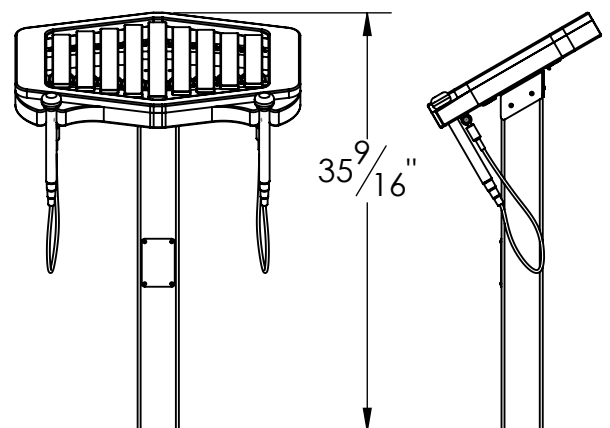

The Rhythm is offered in two post types: Powder Coated Steel and Recycled HDPE. Installation is similar for both post types and varies only slightly in hardware used.

In Ground Mount:

PART NUMBER	DESCRIPTION	RHYT-IG-STL	RHYT-IG-REC
RHYT-BOM	Rhythm Instrument - Pre-Assembly	1	1
POST-STL-72-DEG30-SIGN	In Ground Steel Post, 72"lg. w/ Name Plate	1	-
92970A211	#10 x 3/4" Self Drilling Button Head Screw	4	-
POST-REC-72-DEG30-SIGN	In Ground Recycled Post, 72"lg. w/ Name Plate	-	1
8N125TBTS	#8 x 1-1/4" Button Head Screw	-	4

Surface Mount:

PART NUMBER	DESCRIPTION	RHYT-SM-STL	RHYT-SM-REC
RHYT-BOM	Rhythm Instrument - Pre-Assembly	1	1
POST-STL-36-DEG30-SIGN	Surface Mount Steel Post, 36"lg. w/ Name Plate	1	-
92970A211	#10 x 3/4" Self Drilling Button Head Screw	4	-
POW 07315	3/8"-16 Wedge Expansion Anchor, 3.75"lg. SS	4	-
POST-REC-36-DEG30-SIGN	Surface Mount Recycled Post, 36"lg. w/ Name Plate	-	1
8N125TBTS	#8 x 1-1/4" Button Head Screw	-	4
SM-BASE-REC	Surface Mount Base HDPE, For Recycled Post	-	1
31N500BHLS	5/16" Hex Head Lag Bolt, 5"lg. SS	-	2
POW 07316	3/8"-16 Wedge Expansion Anchor, 5"lg. SS	-	4
9267K43	35/64" Hex Nut Cap	4	4

Portable Mount:

PART NUMBER	DESCRIPTION	RHYT-PM-STL	RHYT-PM-REC
RHYT-BOM	Rhythm Instrument - Pre-Assembly	1	1
RHYT-PM-PS	Rhythm - HDPE Portable Stand (1" Black)	1	1
91185A346	#10-24 Thumb Screw, .5"lg. SS	4	4
HWN0095	3/8"-16 Hex Nut, SS	4	4
POST-STL-36-DEG30-SIGN	Surface Mount Steel Post, 36"lg. w/ Name Plate	1	-
91185A867	3/8"-16 Thumb Screw, 1"lg. SS	4	-
POST-REC-36-DEG30-SIGN	Surface Mount Recycled Post, 36"lg. w/ Name Plate	-	1
SM-BASE-REC	Surface Mount Base HDPE, For Recycled Post	-	1
92185A634	3/8"-16 Socket Head Screw, 2.5"lg. SS	-	4
31N500BHLS	5/16" Hex Head Lag Bolt, 5"lg. SS	-	2
94052A046	3/8" Socket Head Knob	-	4

Before attaching the instrument to the post, determine the desired finished height above ground. Note that the playable surface will be roughly 2-1/2" above the top of the post. Be sure to account for any additional surfacing that may be used.

Surface mount posts come standard at 36"; a lower finished height can be achieved by mounting to a recessed concrete pad or recycled surface mount posts can be cut to length at a 30 degree miter. Posts for in ground mounted variants can be embedded deeper into the ground or cut shorter to achieve the desired height: **NOTE: An embedment depth of at least 36" is required for in ground installations.**

The following are suggested post heights for varying age groups:

Age	Height
2-5	24"
5-12	30"
13+	36"
ASTM*	30"

***For installations targeting compliance with ASTM F1487:** Finished mallet attachment height must not exceed 27" above the underlying surface. This is achieved at a maximum above ground post height of 30".

Step 1: With two people, situate the holster installed on the instrument onto the angled end of the post. Align the holes in each holster with the pre-drilled holes in the post.

Step 2: Using the provided driver bit, fasten the instrument to the post with either the (8) #10 x 3/4" Self Drilling Button Head Screws if mounting to steel posts, or (8) #8 x 1-1/4" Button Head Screws if mounting to recycled posts.

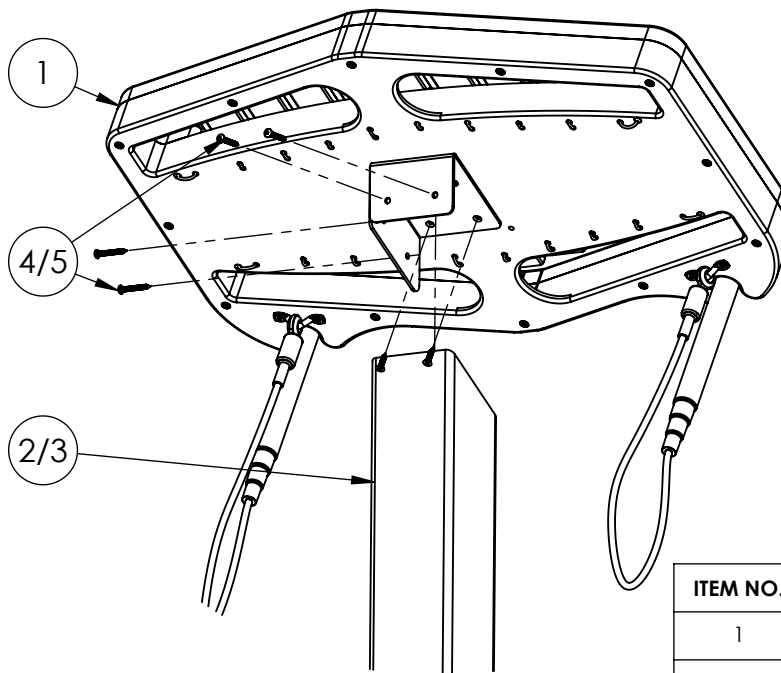

ITEM NO.	DESCRIPTION	STL	REC
1	Rhythm Instrument - Pre-Assembly	1	1
2	Steel Post	1	-
3	Recycled Post	-	1
4	#10 x 3/4" Self Drilling Button Head Screw	4	-
5	#8 x 1-1/4" Button Head Screw	-	4

Step 1: Determine the installation location. A 36" perimeter around the instrument is recommended for wheelchair accessibility. Review the desired finished height. Excavate one 10" diameter hole, at least 36" deep, at the installation location. If a lower height is desired, the post can be cut to length or a deeper embedment depth can be used. Be sure to account for any additional surfacing thickness.

For installations targeting compliance with ASTM F1487: Note that the finished mallet attachment height must not exceed 27" above the underlying surfacing in order to maintain ASTM compliance. This is achieved at a maximum finished post height of 30" measured to the top of the angled cut.

Step 2: With two people, lower the instrument post into the excavated hole. Verify correct orientation and levelness of the instrument.

Step 3: Pour concrete around the post. It is recommended to brace the instrument to hold it stable while the concrete cures. Leave to set according to the concrete manufacturer's guidelines. Approximately (3) 80lb. bag will be needed.

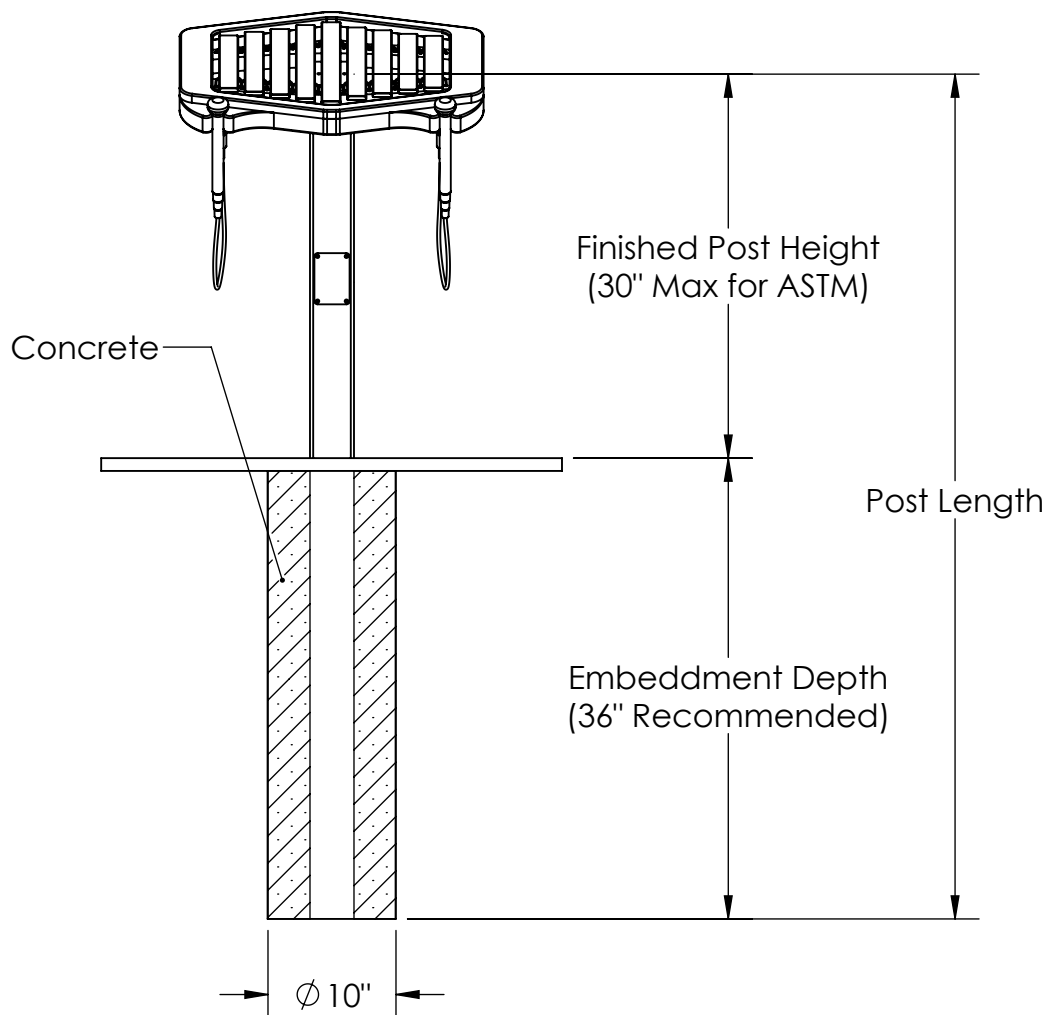

Step 1: Determine installation location. A 36" perimeter around the instrument is recommended for wheelchair accessibility. Review the desired finish height. The standard finished height for a Surface Mount post is 36". If a shorter height is desired, the post can be mounted to a recessed concrete pad, or recycled posts can be cut to length at a 30 degree miter. Be sure to account for any additional surfacing thickness.

For installations targeting compliance with ASTM F1487: Note that all mounting hardware must be covered by surfacing and the finished mallet attachment height must not exceed 27" in order to maintain ASTM compliance. This requires mounting to a concrete pad that has been recessed at least 6" beneath surface level or removal of 6" of post length.

Step 2: Verify concrete pad is a minimum of 24" long x 24" wide x 6" thick. If a new pad is being poured, approximately (4) 80lb. bags of concrete will be needed. Allow concrete to cure per the concrete manufacturer's guidelines.

Step 3: With two people, place the instrument onto the concrete pad and mark the center of the holes on the surface mount base. After you have made your marks, set the instrument aside. With a hammer or rotary drill, drill into the concrete at the marked locations with a 3/8" masonry bit to a minimum depth of 4".

Step 3: Place the Instrument back over the drilled holes. Insert the anchor bolts, 3-3/4" long for steel posts and 5" long for recycled posts. Position the anchor nut so that it is flush with the top of the bolt. Pound anchor bolts into the hole until the washer is flush with the surface mount base. Tighten anchor bolt nuts until they are snug. Cover the protruding bolt sections with the provided nut caps.

If installing onto wet concrete, follow the wet set anchor manufacturer's guidelines for installation.

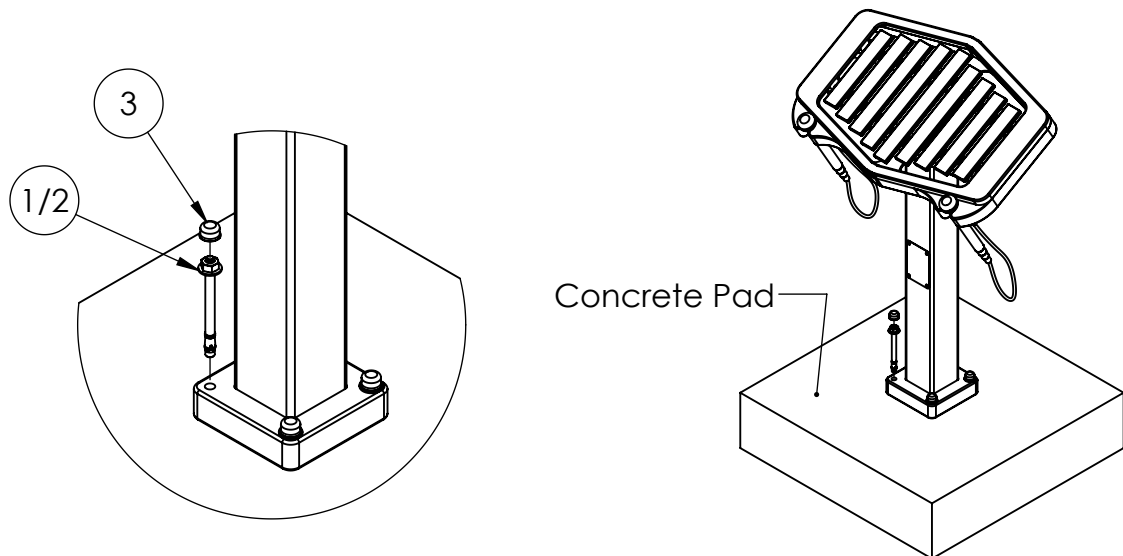

ITEM NO.	DESCRIPTION	RHYT-SM-REC	RHYT-SM-STL
1	3/8"-16 Wedge Expansion Anchor, 3.75"lg. SS	-	4
2	3/8"-16 Wedge Expansion Anchor, 5"lg. SS	4	-
3	35/64" Hex Nut Cap	4	4

Step 1: With two people, situate the instrument onto the portable stand and align the holes in the base of the post.

Step 2: While one person holds the instrument steady, secure the instrument to the portable stand with the (8) 3/8"-16 Thumb Screws, 1" long for steel posts and 2-1/2" long for recycled posts. The 3/8"-16 Hex Nuts come pressed into the portable stand from the factory.

NOTE: Per ASTM F1487, portable equipment does not fulfill the requirements for installation in a playground environment and should be enjoyed in a separate sound garden setting.

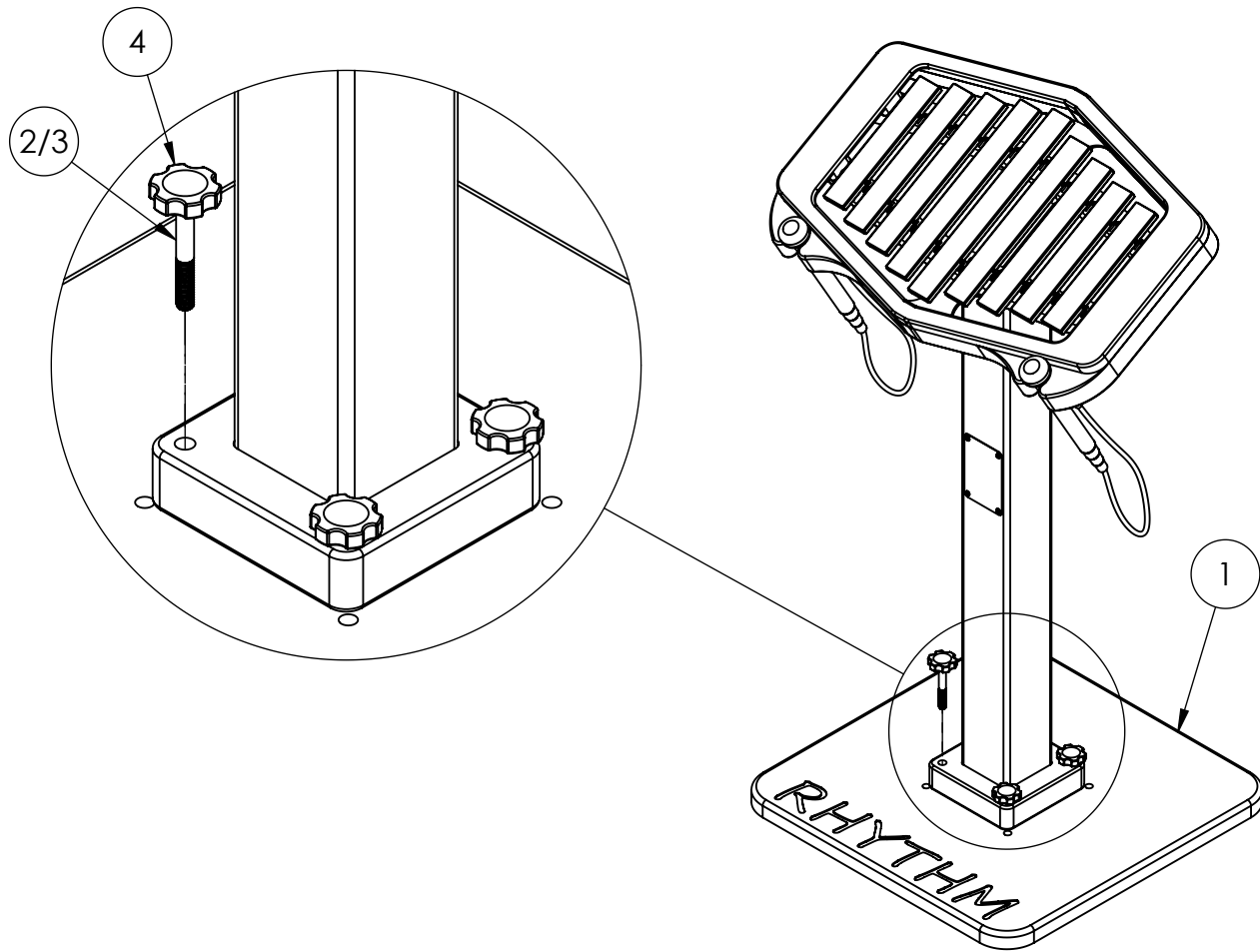

ITEM NO.	DESCRIPTION	RHYT-PM-STL	RHYT-PM-REC
1	Rhythm - HDPE Portable Stand (1" Black)	1	1
2	3/8"-16 Thumb Screw, 1"lg. SS	4	-
3	3/8"-16 Socket Head Screw, 2.5"lg. SS	-	4
4	3/8" Socket Head Knob	-	4
5	3/8"-16 Hex Nut, SS	4	4